

PIO 31 M 0.1k UH
PIO Series SMD Power Inductor

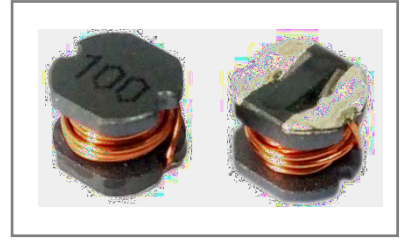

1. Operation Temperature

1. Feature

- Ultra-thin design
- F8 >> 3M Cj > u
- Suitable for surface mounting

1. Application

- Portable communication equipment, Notebook
- DC/DC conversion
- DC switching power supply circuit

1. Part Number

PIO	43	1R0	M	T
Product Code	p. (Kµ×Q) Dimension (Length × Thickness)	+k uH Inductance	¢ \$ Tolerance	; > u - Packaging code
PIO	43 : 4.5×3.2mm 54 : 5.8×4.5mm 75 : 7.8×5.0mm	R10 : 0.1 uH 1R0 : 1.0 uH 100 : 10 uH 101 : 100 uH 102 : 1000 uH	K : ±10% M : ±20% N : ±30%	T : - \ - > u Tape & Reel

1. Product Structure

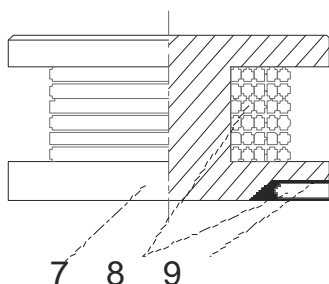

No.	G f Component	† ĩ Material
7	.:8â Core	KfKBJ÷"] %Ni-Zn Ferrite
8	4ô > Winding	%< ;4ô Enamelled Wire
9	+k · Electrodes	Ë x —K, Bottom Layer—Ag Kv x—Kf x Electroplated Coating—Ni Kv x—KW x Electroplated Coating—Sn >ž x—KWK Surface Layer—Sn/Cu

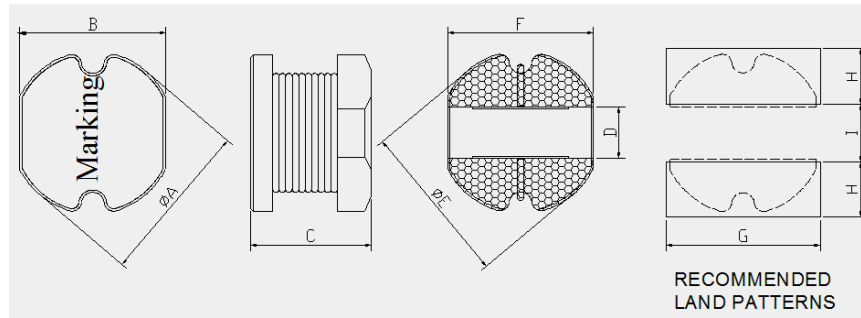
1 ?ú r p .
Dimension

‹ f (Unit) Ömm

Á - Part	A	B	C	D (Typ.)	E (Typ.)	F (Typ.)	G (Typ.)	H (Typ.)	I (Typ.)
PIO43	4.5±0.3	4.0±0.3	3.2±0.3	1.6	4.5	4.0	4.5	1.75	1.5
PIO54	5.8±0.3	5.2±0.3	4.5±0.3	2.0	5.8	5.2	5.5	2.15	1.7
PIO75	7.8±0.3	7.0±0.3	5.0±0.3	2.5	7.8	7.0	7.5	3.0	2.0

1
Electrical Characteristics
PIO43 Type

?ú r Á - Part No.	+k UH Inductance (µH)	¢ \$ Tolerance	#•B NÇ)½ Test Freq.	-*#w+kLq Direct Current Resistance DCR()Max	NÓ Đ+k#w Rated DC Current IDC (A)
PIO43-1R0MT	1.0	±20%	100KHz	0.045	3.50
PIO43-1R5MT	1.5	±20%	100KHz	0.055	2.85
PIO43-2R2MT	2.2	±20%	100KHz	0.070	2.40
PIO43-2R7MT	2.7	±20%	100KHz	0.075	2.30
PIO43-3R3MT	3.3	±20%	100KHz	0.085	2.25
PIO43-3R9MT	3.9	±20%	100KHz	0.090	1.70
PIO43-4R7MT	4.7	±20%	100KHz	0.105	1.65

PIO43-101KT	100	±10%	1KHz	1.400	0.40
PIO43-121KT	120	±10%	1KHz	1.500	0.38
PIO43-151KT	150	±10%	1KHz	2.000	0.35
PIO43-181KT	180	±10%	1KHz	2.120	0.30
PIO43-221KT	220	±10%	1KHz	2.460	0.27

PIO54 Type

Part No.	+k UH Inductance (µH)	±% Tolerance	#•B NÇ)½ Test Freq.	-*#w+kLq Direct Current Resistance DCR()Max	NÓ Đ+k#w Rated DC Current IDC (A)
PIO54-R47NT	0.47	±30%	100KHz	0.012	4.80
PIO54-1R0MT	1.00	±20%	100KHz	0.025	3.50
PIO54-1R5MT	1.50	±20%	100KHz	0.025	3.30
PIO54-2R2MT	2.20	±20%	100KHz	0.028	3.20
PIO54-2R7MT	2.70	±20%	100KHz	0.030	3.00
PIO54-3R3MT	3.30	±20%	100KHz	0.035	2.50
PIO54-3R9MT	3.90	±20%	100KHz	0.038	2.40
PIO54-4R7MT	4.70	±20%	100KHz	0.040	2.30
PIO54-5R6MT	5.60	±20%	100KHz	0.050	2.10
PIO54-6R8MT	6.80	±20%	100KHz	0.055	2.00
PIO54-7R2MT	7.20	±20%	100KHz	0.070	1.80
PIO54-8R2MT	8.20	±20%	100KHz	0.090	1.70
PIO54-100MT	10	±20%	100KHz	0.100	1.65
PIO54-120MT	12	±20%	100KHz	0.120	1.55
PIO54-150MT	15	±20%	100KHz	0.140	1.40
PIO54-180MT	18	±20%	100KHz	0.150	1.25
PIO54-220MT	22	±20%	100KHz	0.180	1.10
PIO54-270MT	27	±20%	100KHz	0.200	0.95
PIO54-330MT	33	±20%	100KHz	0.220	0.90
PIO54-390MT	39	±20%	100KHz	0.300	0.80
PIO54-470MT	47	±20%	100KHz	0.350	0.75
PIO54-560MT	56	±20%	100KHz	0.400	0.70
PIO54-680MT	68	±20%	100KHz	0.450	0.65
PIO54-820MT	82	±20%	100KHz	0.600	0.60
PIO54-101KT	100	±10%	1KHz	0.700	0.55
PIO54-121KT	120	±10%	1KHz	0.850	0.45
PIO54-151KT	150	±10%	1KHz	1.100	0.43
PIO54-181KT	180	±10%	1KHz	1.350	0.40
PIO54-221KT	220	±10%	1KHz	1.550	0.35
PIO54-331KT	330	±10%	1KHz	1.760	0.30
PIO54-391KT	390	±10%	1KHz	2.500	0.27
PIO54-471KT	470	±10%	1KHz	2.500	0.25
PIO54-561KT	560	±10%	1KHz	2.870	0.20
PIO54-681KT	680	±10%	1KHz	3.500	0.18

PIO54-821KT	820	±10%	1KHz	5.200	0.17
PIO54-102KT	1000	±10%	1KHz	5.500	0.15
PIO54-122KT	1200	±10%	1KHz	6.400	0.13

PIO75 Type

Part No.	+k UH Inductance (μH)	±% Tolerance	#*B NÇ)½ Test Freq.	-*#w+kLq Direct Current Resistance DCR()Max	NÓ Ð+k#w Rated DC Current IDC (A)
PIO75-1R0MT	1.0	±20%	100KHz	0.015	5.80
PIO75-1R5MT	1.5	±20%	100KHz	0.017	5.50
PIO75-2R2MT	2.2	±20%	100KHz	0.018	5.20
PIO75-2R7MT	2.7	±20%	100KHz	0.023	5.00
PIO75-3R3MT	3.3	±20%	100KHz	0.025	4.80
PIO75-3R9MT	3.9	±20%	100KHz	0.027	4.20
PIO75-4R7MT	4.7	±20%	100KHz	0.028	4.00
PIO75-5R6MT	5.6	±20%	100KHz	0.030	3.80
PIO75-6R8MT	6.8	±20%	100KHz	0.040	3.00
PIO75-8R2MT	8.2	±20%	100KHz	0.042	2.70
PIO75-100MT	10	±20%	100KHz	0.070	2.55
PIO75-120MT	12	±20%	100KHz	0.080	2.40
PIO75-150MT	15	±20%	100KHz	0.090	2.00
PIO75-180MT	18	±20%	100KHz	0.100	1.95
PIO75-220MT	22	±20%	100KHz	0.110	1.70
PIO75-270MT	27	±20%	100KHz	0.120	1.55
PIO75-330MT	33	±20%	100KHz	0.130	1.40
PIO75-390MT	39	±20%	100KHz	0.150	1.35
PIO75-470MT	47	±20%	100KHz	0.190	1.25
PIO75-560MT	56	±20%	100KHz	0.230	1.10
PIO75-680MT	68	±20%	100KHz	0.250	1.00
PIO75-820MT	82	±20%	100KHz	0.350	0.95
PIO75-101KT	100	±10%	1KHz	0.400	0.78
PIO75-121KT	120	±10%	1KHz	0.450	0.73
PIO75-151KT	150	±10%	1KHz	0.600	0.70
PIO75-181KT	180	±10%	1KHz	0.700	0.60
PIO75-221KT	220	±10%	1KHz	0.950	0.55
PIO75-271KT	270	±10%	1KHz	1.100	0.50
PIO75-331KT	330	±10%	1KHz	1.250	0.45
PIO75-391KT	390	±10%	1KHz	1.750	0.40
PIO75-471KT	470	±10%	1KHz	1.950	0.35
PIO75-561KT	560	±10%	1KHz	1.980	0.32
PIO75-681KT	680	±10%	1KHz	2.180	0.31
PIO75-821KT	820	±10%	1KHz	2.880	0.30
PIO75-102KT	1000	±10%	1KHz	3.850	0.20
PIO75-152KT	1500	±10%	1KHz	5.200	0.18

PIO75-182KT	1800	±10%	1KHz	7.000	0.16
PIO75-202KT	2000	±10%	1KHz	7.000	0.16
PIO75-222KT	2200	±10%	1KHz	8.300	0.15

≠# Æ#•B +k Å p 0.5V >

Remarks: The test voltage is 0.5V.

IDC Æ = μ+k UH " S r ALf L+k U ž>žM`\$ _ Ü @ } ,°+k#w r ' ø69 ž *)ã 1\$ _ Ü μ >

IDC Æ The DC current at which cause a 10% inductance reduction from the initial value or inductor surface temperature to rise by 40 , whichever is smaller. (Reference ambient temperature 20).

1 %M–]#•B i#

Reliability Test Method

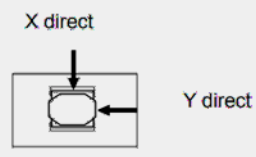
Å - No.	N-\$ Items	?."x Requirements	B PÅ i# =# Test Methods and Remarks
1	5 5N+kLq Insulation Resistance	H00M0	^+k U ž46 > Å.÷8ã •L* ó Ö 100 V -#*w+k Å 7 60s > 100 V DC between inductor coil and core for 60 seconds.
2	%@] Solderability	+k .M` @?¼- æ,°@ ï > 95% or more of electrode area shall be coated by new solder.	^ 245±5 'Ê=Ã,°@KVÄ96.5Sn/3.0Ag/0.5Cu Å c#® 5±1s Å Dip pads in flux and dip in solder pot (96.5Sn/3.0Ag/0.5Cu) at 245±5 for (5±1) seconds.
3	6F'@ Û# Resistance to Soldering Heat	L?ø %?÷ p æ • Z Ç +k UH L)½ Æ±10% » > No visible mechanical damage. Inductance change: Within ±10%	^ 260±5 'Ê=Ã,°@KVÄ96.5Sn/3.0Ag/0.5Cu Å c#® 10±1s Å Dip pads in flux and dip in solder pot (96.5Sn/3.0Ag/0.5Cu) at 260±5 for (10±1) seconds.
4	1% † p Ü Terminal Strength	y,1% † ' Þ = 7g:s > No looseness of shedding of terminals.	μ+^@ ï <+k U ž'@ Û fB PÅ μ @ ,!D ?1ã j i G < a ó 10N ,° Ñ , 7 ,L* 10±1s > The inductor is welded to the test plate with solder, and then applied 10 N force in the direction of arrow and kept for 10 ± 1s. 
5	6FQ \$ _ High Temperature	L?ø %?÷ p æ • Z Ç +k UH L)½ Æ f » > No visible mechanical damage. Inductance change: Within ±10%	\$ _ Ü f ,L* K , ^ Ú\$ _ A t5ª E , D = E , » #•B > Temperature 85±2 , time 1000*²h, test within 48 hours after 2 hours of placement at room temperature.
6	6F „ \$ _ Low Temperature	L?ø %?÷ p æ • Z Ç +k UH L)½ Æ f » > No visible mechanical damage. Inductance change: Within ±10%	\$ _ Ü f ,L* K Ç ^ Ú\$ _ A t5ª E , D = E , » #•B > Temperature -40 ± 2 , time 1000*²h, test within 48 hours after 2 hours of placement at room temperature.
7	\$ _ Ü è 1 Thermal Shock	L?ø %?÷ p æ • Z Ç +k UH L)½ Æ±10% » > No visible mechanical damage. Inductance change: Within ±10%	(-40±3 μ , ,L* (30±3) min < (85±2) /(30±3) min ,Eç ~ ,L* (2-3) min , à)ã 32 !W Ç ^ Ú\$ _ A t5ª 2 E , D = 48 E , » #•B > The test sample shall be placed at (-40±3) and (85±2) for (30±3) min, different temperature conversion time is 2~3 minutes. The temperature cycle shall be repeated 32 cycles. Test within 48 hours after 2 hours of placement at room temperature.
8	\$ _ Ü (~] Temperature Characteristic	+ k UH L) ½ P_c-b, P_c-d C C » E ý ^ 1 40 . 85 , °)ã 1 A#•H +k UH r , < a D 20)ã 1 A#• H ,°+k UH F > , " E' > Inductance change P_c-b, P_c-d. Within ±20%	Based on the inductance at 20 and Measured at the ambient of 1 40 . 85 .
9	^ Ð\$μ# Constant Damp Heat	L?ø %?÷ p æ • Z Ç +k UH L)½ Æ±10% » > No visible mechanical damage. Inductance change: Within ±10%	<+k U ž t5ª ^ Å\$μ Ü (90-95)%RH, \$ _ Ü 60±2 , °)ã 1 c ž t 1000*²H , ^ Ú\$ _ A t5ª 2 E , D = 48 E , » #•B > The inductors were stored for 1000 + 240 h at humidity (90-95)%RH, temperature 60±2 , and tested within 48h after 2H at room temperature.

'5# @>ž Continue the above table μ

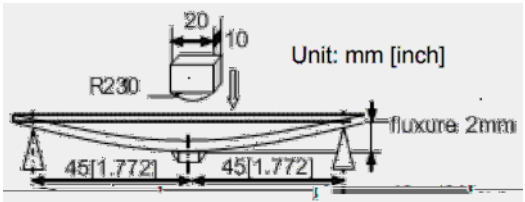
Å - No.	N-\$ Items	?-"x Requirements	B PÅ i# =# Test Methods and Remarks
10	e P Vibration	L?ø %?÷ p æ • Z Ç +k UH L)½ Æ±10% » > No visible mechanical damage. Inductance change: Within ±10%	<p>μ+^'@ Ĩ <+k U ž'@ Ū fB PÅ μ @ ,B PÅ μ 0 Đ Ā e P B PÅ o - μ • D e P & P JF Ū >B PÅ ? A — ,F > ,Æ e P NÇ)½ 99 * Æ 0Hz 55Hz e { Æ 1.5mm ' ÖFU Ū O 196m/s² μ 6!W à)à ,L* Æ 1min ' 10Hz : 55Hz : 10Hz μ e P ,L* Æ X/Y/Z E^a: 2H ' § 6H μ</p> <p>The inductor is welded to the test plate with solder, and the test plate is fixed to the vibration test fixture so that it is rigidly connected with the vibration table. The test shall be conducted according to the following conditions: Vibration frequency range: 10Hz~55Hz Amplitude: 1.5mm (Acceleration O 196m/s²) One cycle time: 1min (10Hz : 55Hz : 10Hz) Vibration time: 2 hours for X/Y/Z axis (Total of 6 hours)</p>
11	e (B PÅ Resistance to Flexure	L?ø %?÷ p æ • Z Ç No visible mechanical damage.	<p>μ+^'@ Ĩ <+k U ž'@ Ū fB PÅ μ @ ,I D ó Ö 6` ,-* ĩ G,° Ñ ' , 4 v/p μ ,B PÅ ? A — ,F > ,Æ e (Ū Æ 2mm Ö ÁFU Ū Æ.5mm/s 7 ,L* Æ 30±1s #*B μ Đ Ū Æ 1.0mm</p> <p>The inductor is welded to the test plate with solder, and then apply a vertical force (as shown in the figure). The test shall be conducted according to the following conditions: Curvature: 2mm Pressurization speed: 0.5mm/s Holding time: 30 ± 1s Thickness of test plate: 1.0mm</p> 
12	Q \$ _CUE ³ ' 5 ³ μ High-temperature Load (Life-span)	L?ø %?÷ p æ • Z Ç +k UH L)½ Æ±10% » > No visible mechanical damage. Inductance change: Within ±10%	<p>\$_ Ū 85 ±2 ,L* 1000^{±2}h, ó ÖNÓ Đ+k#w , ^ Ū \$ _ A t5[±] 2 E , D = 48 E , »#*B ></p> <p>Temperature 85 ± 2 , Time 1000^{±2}h , apply a rated current, test within 48 hours after 2 hours of placement at room temperature.</p> <p># Æ ÖE³+k#w ,M, ,>žM"\$ _ Ū C»E†25 ,° ,M6?· /+k#w L fNÓ fM, ,>žM"\$ _ Ū CC»E†25 ></p> <p>Note: If the surface temperature of the part over 125 when the current is loaded, the current need to reduce until the surface temperature of the part less than 125 .</p>

1 ;>û

Packaging

E³\ p .

Tape Dimension

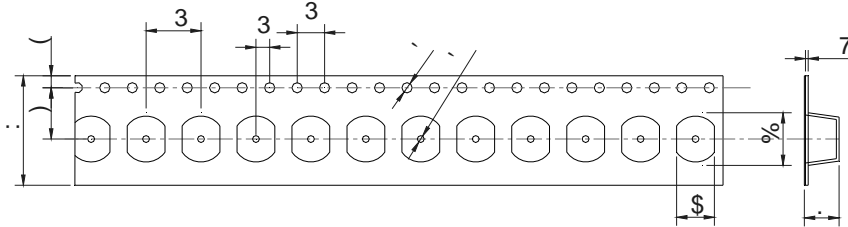

Unit: mm

Part	W	A0	B0	D	D1	E	F	K0	P0	P2	P	T
PIO43	12±0.5	4.3±0.3	4.8±0.3	1.5±0.3	1.5±0.3	1.75±0.3	5.5±0.3	3.6±0.3	4±0.3	2±0.3	8±0.3	0.35±0.1
PIO54	16±0.5	5.5±0.3	6.7±0.3	1.5±0.3	-----	1.75±0.3	7.5±0.3	4.9±0.3	4±0.3	2±0.3	8±0.3	0.40±0.1
PIO75	16±0.5	7.3±0.3	8.1±0.3	1.5±0.3	1.5±0.3	1.75±0.3	7.5±0.3	5.6±0.3	4±0.3	2±0.3	12±0.3	0.375±0.1

-- p. ÑïiG

Reel Size & Direction Of Feed

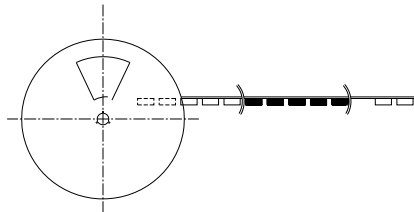

1 9† μ+^,°@ Ū (4ō

Recommended soldering profile

b Ý ÷ 0Aä μ+^ #w@ Ū#

Applicable soldering process to the products is reflow soldering.

'@ Ū † ĩ

'@ Ĩ ÆSn-3.0Ag-0.5Cu

Solder ÆSn-3.0Ag-0.5Cu

ß'@ x Æ μ+^ 'Öĭ 0 ß'@ x ,/! ĩ μ+^ š L(Ÿ aH C»Eý 0.2wt%,° pG@] ß'@ x Ĥ"j\$ĭ] ß'@ x >

Flux: Use rosin-based flux, but not strongly acidic flux (with chlorine exceeding 0.2 wt%). Do not use water-soluble flux.

'@ Ū (4ō

Soldering Profile

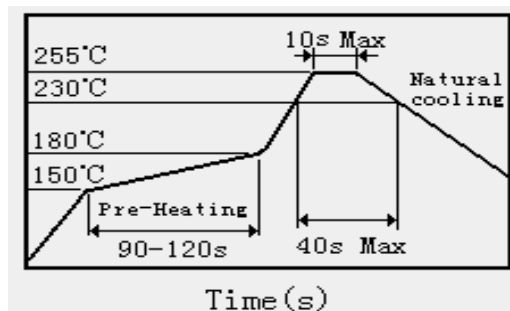

1 Cd Ž?."x

Storage Requirements

Ž Þ UL† Æ p A÷+k U,°@ Ū(-] Ĥ ;>ŭ † ĩ : Ä8¥ ³(i 7 ,B- Ä b ø . C] D 6 ` > » μ+^ b Ý ÷ > B , ,+g Ä+k U

,°@ Ū(-] PLÄ ,L* +U L , , ÒCd Ž ,L*C»Eý 6 ` > ,B-Oĭ ~.ªAU -'@ Ū(-] D Ä μ+^ >

Storage Period: In order to ensure that the welding characteristics and packaging materials of the inductor are in good condition, please use this product within 6 months after the company ships it. At the same time, because the welding characteristics of the inductor will change with time, if the storage time exceeds 6 months, please confirm its welding characteristics before use.

Ž Þ — , Æ

\$_ Ū Æ10 to +40 '5L \ ;>ŭ ,°+k U ž μ Ç -40 to +85 ' +k U ž b %o μ

-. /\$μ Ū Æ 30~70%RH

Storage Conditions Æ

Temperature: -10 to +40 (Inductors With Taping); -40 to +85 (Inductors Body)

Humidity Æ30~70%RH