

磁棒电感器

Magnetic Rod Coils

特征

Feature

- * 优良的焊接性和耐焊性，适合于波峰焊。
Excellent solderability and heat resistance for reflow soldering.
- * 工业生产标准尺寸及多种脚型产品。
Standard size, various lead configuration.

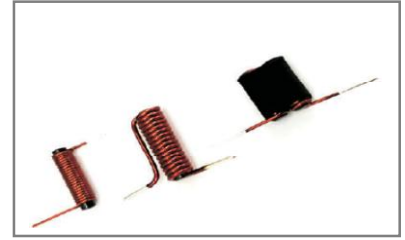

应用

Application

- * 一般用途品
General purpose goods

订货代码

How To Order

- * 举例
For Example

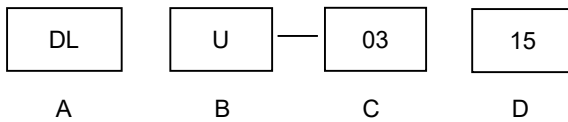

项目 Item	代码 code	描述 Description
A	DL	磁棒电感 Magnetic Rod Coils
B	U	封装形式：UL 套管 代码空缺表示无封装 Packaging form: UL sleeve Code vacancy means no encapsulation
C	03	磁芯外径 Core diameter
D	15	磁芯长度 Core length

外型尺寸
Size code,

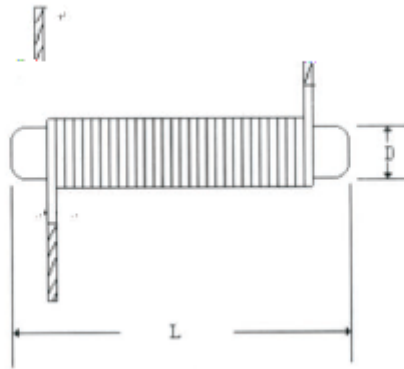

Type	Dimensions(mm)	
	L	D
ADL2510	2.0	10
ADL0312	3.0	12
ADL0315	3.0	15
ADL0415	4.0	15
ADL0520	5.0	20
ADL0615	6.0	15
ADL0620	6.0	20
ADL0625	6.0	25

#

The products can be customized according to customer requirement.

主要电性能参数

ELECTRICAL CHARACTERISTICS

型号 Part Number	电感量 L (μ H)
ADL2510	0.5-15
ADL0312	0.5-15
ADL0315	0.5-15
ADL0415	0.5-15
ADL0520	0.5-15
ADL0615	0.5-15
ADL0620	0.5-15
ADL0625	0.5-15

#

The products can be customized according to customer requirement.

可靠性测试方法
Reliability Test Method

组别 Group	试验项目 Test items	试验方法 test method	判定标准 Criteria
1	1.1 appearance	在适当的光源和放大设备上进行检查 Check on appropriate light source and magnification equipment	Meet the requirements of product standards
	1.2 size	0.02mm Measure with a measuring tool with an accuracy of no less than 0.02mm.	
	1.3 Electrical performance	Test with the appropriate tester	
2.1	Weldability	焊锡温度: 255°C ± 5°C 浸渍时间: 2.5s ± 0.5s Solder temperature: 255 5 Immersion time: 2.5s ± 0.5s	≥95% Tinning rate 95%
2.2	Steady damp-heat	试验温度: 40°C ± 2°C 试验湿度: (90%~95%) RH 试验时间: 500 h ± 2 h 恢复时间: 24 h ± 2 h Test temperature: 40 °C ± 2 °C Test humidity: (90%~95%) RH Test time: 500 h ± 2 h Recovery time: 24 h ± 2 h	-10% ≤ L/L ≤ 10% There is no obvious damage to the appearance, -10% L/L 10%
2.3	Core drawing force	拉拔力测试仪 Pulling force tester	≥5kg
2.4	flammability	1m 高度自由落下水泥地, 3 次 Free fall on the cement floor at a height of 1m, 3 times	There is no obvious damage to the appearance, and the electrical performance of the product meets the requirements
2.5	Resistance to welding heat	将元件浸入锡炉内, 浸渍到锡面平齐产品本体最低点 (即平齐磁芯底部端面或套管底部端面), 焊锡温度为 350°C ± 5°C, 浸渍时间为 3s ± 0.5s Immerse the element in the tin furnace, and immerse it to the lowest point of the tin surface flush with the product body (i.e. flush the bottom end face of the magnetic core or the bottom end face of the sleeve). The soldering temperature is 350 °C ± 5 °C, and the immersion time is 3s ± 0.5s	There is no obvious damage to the appearance,

	2.6	Temperature shock	试验温度/温区保持时间: 阶段 1: +125°C/30min 阶段 2: -40°C/30min 循环次数: 10 次, 转换时间<5min 恢复时间: 2 h Test temperature/temperature zone holding time: Phase 1:+125 /30min Stage 2: - 40 /30min Cycle times: 10 times, switching time 5min Recovery time: 2 h	
	2.7	working life	试验温度: 85°C±2°C 施加额定的直流电流 试验时间: 1000 h 恢复时间: 24 h±2 h Test temperature: 85 °C± 2 °C Apply rated DC current Test time: 1000 h Recovery time: 24 h ± 2 h	There is no obvious damage to the appearance,
	2.8	High temperature resistance	试验温度: (125±2) °C 试验时间: 96h±2h 恢复时间: 2h Test temperature: (125 2) Test time: 96h ± 2h Recovery time: 2h	
	2.9	Low temperature resistance	试验温度: (-40±2) °C 试验时间: 96h±2h 恢复时间: 2h Test temperature: (- 40 ± 2) °C Test time: 96h ± 2h Recovery time: 2h	
	2.10	Vibration	振动频率: 10Hz~55Hz 全振幅: 1.5mm 水平、垂直方向各 2h Vibration frequency: 10Hz~55Hz Full amplitude: 1.5mm 2h in horizontal and vertical directions respectively	外观无异常, 电气性能符合要求 The appearance is normal, and the electrical performance meets the requirements